

MINK MV 0312 B

Dry claw vacuum pump



VACUUM SOLUTIONS



Quiet

Low noise level due to a state-of-the-art acoustic design, can be installed at workstations

Efficient

Latest claw vacuum technology, low energy consumption, minimized operating costs, nearly maintenance-free, effective air cooling

Compact

Small footprint

MINK MV 0312 B

Dry claw vacuum pump



VACUUM SOLUTIONS

Dimensional drawing

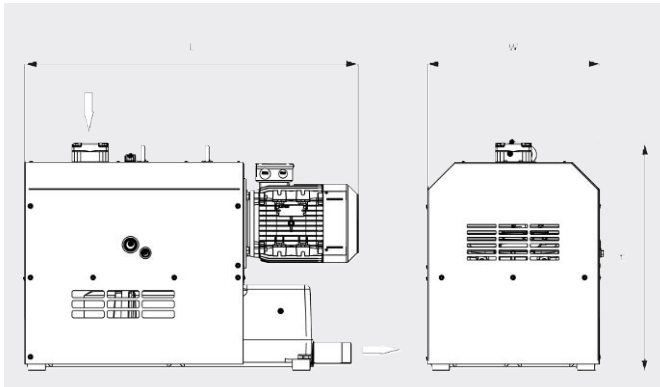

Pumping speed

Air at 20°C. Tolerance: ± 10%

— 50 Hz 60 Hz

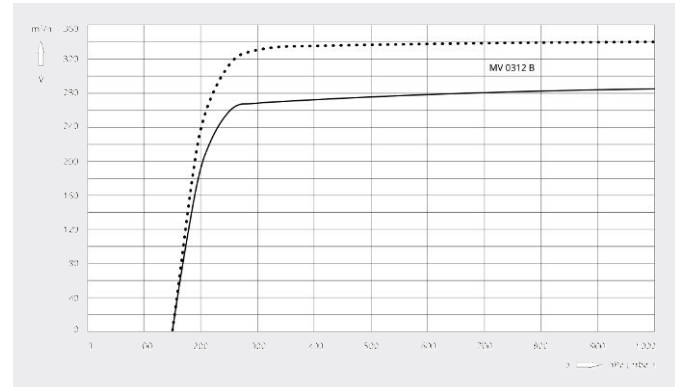

MINK MV 0312 B	
Nominal pumping speed	290 / 345 m³/h (50 / 60 Hz)
Ultimate pressure	150 hPa (mbar) (50 / 60 Hz)
Nominal motor rating	5.5 / 6.5 kW (50 / 60 Hz)
Nominal motor speed	3000 / 3600 min ⁻¹ (50 / 60 Hz)
Noise level (ISO 2151)	69 / 72 dB(A) (50 / 60 Hz)
Weight approx.	300 kg
Dimensions (L x W x H)	940 x 500 x 650 mm
Gas inlet / outlet	G 2" / R 1¼"

DO YOU WANT TO KNOW MORE?

Get in touch with us directly!



CONTACT FORM